



SAC

GLASSLINED ACCUMULATORS
FOR SANITARY HOT WATER (300 - 5.000 LITRES)



SAC 300 - 500 - 800 - 1000

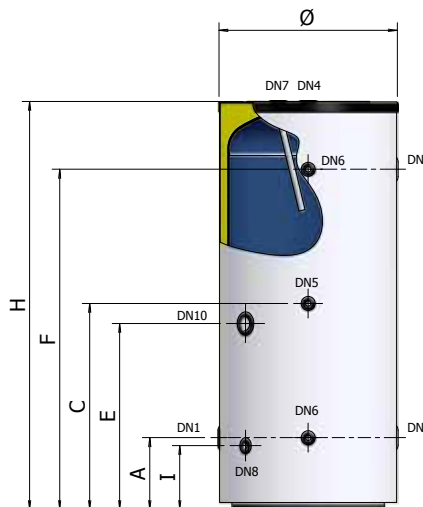
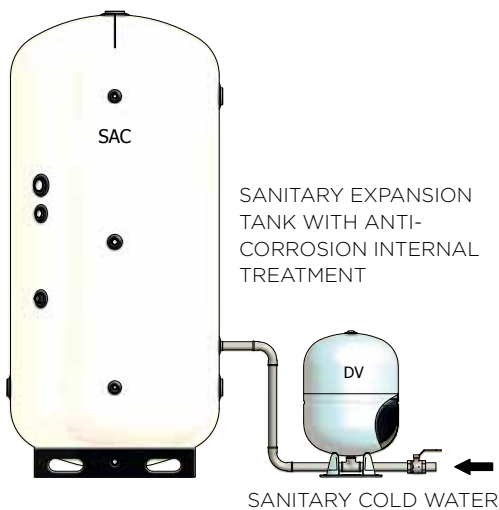

SAC 1500 - 2000 - 3000 - 5000

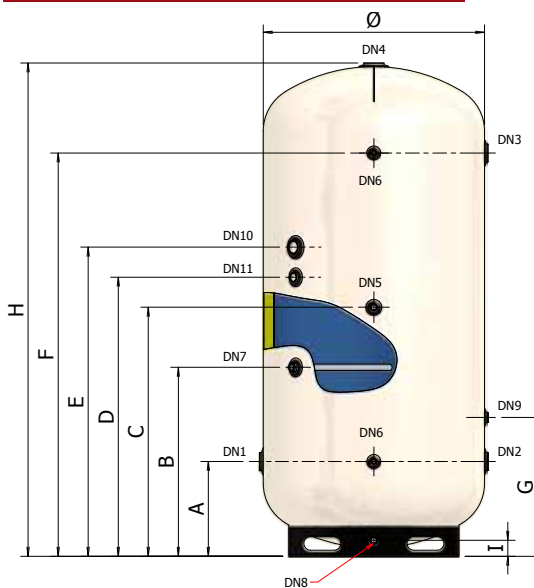

KEYWORD

DN1: Sanitary cold water inlet; **DN2:** Sanitary water outlet (external heat exchanger); **DN3:** Sanitary hot water inlet (from external heat exchanger); **DN4:** Sanitary hot water outlet; **DN5:** Recirculation; **DN6:** Probes; **DN7:** Magnesium anode; **DN8:** Drain; **DN9:** Sanitary expansion tank connection; **DN10:** Heating element; **DN11:** Predisposition for auxiliary magnesium anode.

- FOR SANITARY HOT WATER
- MAGNESIUM ANODE
- HANDLING BY FORKLIFT
- INTERNAL, GLASSLINING ANTI-CORROSION TREATMENT
- POLYURETHANE INSULATION
- + 95°C WORKING TEMPERATURE
- P_{MAX} 10 bar (300 - 1000) MAX WORKING PRESSURE
- P_{MAX} 6 bar (1500 - 5000) MAX WORKING PRESSURE

WARRANTY: 5 YEARS

INSULATION:

EXPANDED POLYURETHANE

REFERENCE STANDARDS

ACCUMULATOR:

Directive PED 97/23/EC - ART. 3.3, without CE marking
Standard EN 12897:2006

INTERNAL GLASSLINING:



DIN 4753

The glasslining treatment makes the accumulator suitable to contain hot water for sanitary and hygienic use and resistant to corrosive phenomena.

INSTALLATION:

- traditional boilers (wall-hung and/or floor-standing)
- condensing boilers
- solar thermal systems

DIMENSIONS

MODEL	CODE	LITRES	mm		NOTES
					
SAC-300	A3IOL51 PGP40	300	650	1400	
SAC-500	A3IOL55 PGP40	500	750	1695	
SAC-800	A3IOL60 PGP40	800	900	1780	
SAC-1000	A3IOL62 PGP40	1000	900	2030	
SAC-1500	A3IOH67 VW050	1500	1100	2460	
SAC-2000	A3IOH70 VW050	2000	1200	2445	
SAC-3000	A3IOH74 VW050	3000	1350	2840	
SAC-5000	A3IOH80 VW050	5000	1700	3040	

MODEL	A mm	B mm	C mm	D mm	E mm	F mm	G mm	I mm
SAC-300	280	/	710	/	640	1140	/	245
SAC-500	300	/	855	/	770	1410	/	265
SAC-800	350	/	905	/	860	1460	/	320
SAC-1000	360	/	1030	/	930	1700	/	320
SAC-1500	475	945	1245	1395	1545	2015	695	80
SAC-2000	465	935	1235	1385	1535	2005	685	80
SAC-3000	525	980	1425	1580	1730	2330	730	80
SAC-5000	635	1085	1535	1685	1835	2435	835	80

ANODE

MODEL	∅ x ∅ conn. x L	DN1	DN2	DN3	DN4	DN5	DN6	DN7	DN8	DN9	DN10	DN11
SAC-300	32 x 1.1/4" x 350	1.1/4"	1.1/4"	1.1/4"	1.1/4"	3/4"	1/2"	1.1/4"	1/2"	/	2"	/
SAC-500	32 x 1.1/4" x 410	1.1/2"	1.1/2"	1.1/2"	1.1/4"	3/4"	1/2"	1.1/4"	1/2"	/	2"	/
SAC-800	32 x 1.1/4" x 520	1.1/2"	1.1/2"	1.1/2"	1.1/4"	3/4"	1/2"	1.1/4"	3/4"	/	2"	/
SAC-1000	32 x 1.1/4" x 520	2"	2"	2"	1.1/4"	3/4"	1/2"	1.1/4"	3/4"	/	2"	/
SAC-1500	32 x 1.1/4" x 670	2.1/2"	2.1/2"	2.1/2"	3"	3/4"	1/2"	1.1/4"	1"	1.1/4"	2"	1.1/4"
SAC-2000	32 x 1.1/4" x 670	2.1/2"	2.1/2"	2.1/2"	3"	3/4"	1/2"	1.1/4"	1"	1.1/4"	2"	1.1/4"
SAC-3000	32 x 1.1/4" x 700	3"	3"	3"	3"	3/4"	1/2"	1.1/4"	1"	1.1/4"	2"	1.1/4"
SAC-5000	40 x 1.1/2" x 640	3"	3"	3"	3"	3/4"	1/2"	1.1/2"	1"	1.1/4"	2"	1.1/2"

TECHNICAL CHARACTERISTICS

MODEL	MAX WORKING PRESSURE CYLINDER (Secondary circuit)	MAXIMUM WORKING TEMPERATURE
SAC-300	10 bar	95 °C
SAC-500		
SAC-800		
SAC-1000		
SAC-1500	6 bar	95 °C
SAC-2000		
SAC-3000		
SAC-5000		

MODEL	INSULATION TYPE	INSULATION THICKNESS	INSULATION DENSITY	INITIAL THERMAL CONDUCTIVITY	(*) INSULATION THERMAL LOSS	EXTERNAL COVER
SAC 300	95% closed cells rigid expanded polyurethane, CFC - HCFC free	50 mm	40 kg/m ³	23,5 mW/m K	1,29 kWh / 24h	Grey polystyrene RAL 9006
SAC 500					1,84 kWh / 24h	
SAC 800					2,37 kWh / 24h	
SAC 1000					2,71 kWh / 24h	
SAC 1500	Open cells flexible expanded polyurethane	50 mm	15 kg/m ³	39,0 mW/m K	6,53 kWh / 24h	Skay white RAL 9001
SAC 2000					7,15 kWh / 24h	
SAC 3000					9,18 kWh / 24h	
SAC 5000					12,27kWh / 24h	

SAFETY DEVICES

- The cylinders must be protected against the effects of over pressure by installing:
- A **SAFETY VALVE** calibrated to pressure below the max pressure of the accumulator
 - A **SANITARY EXPANSION TANK** mod. ELBI **D - DV series**

MODEL	RECOMMENDED SANITARY EXPANSION TANK (mod. ELBI D-DV series)
SAC 300	D - 24
SAC 500	D - 35
SAC 800	DV - 50
SAC 1000	DV - 80
SAC 1500	DV - 150
SAC 2000	DV - 150
SAC 3000	DV - 300
SAC 5000	n°2 pcs DV - 200

Sized using the following parameters: T. accumulation= 85 °C / T. inlet = 15 °C / Pre-charge pressure = 3 bar / Max pressure = 6 bar
The recommended capacity must be verified on the basis of the actual dimensions of the system implemented.

MODEL	MAGNESIUM ANODE SUPPLIED	CATHODIC PROTECTION APPLICABLE
SAC 300	1.1/4" x 320 / Cod. 8560040	Cathodic protection for cylinders 100/400 l. Code 8560170
SAC 500	1.1/4" x 410 / Cod. 8560050	Cathodic protection for cylinders 500/1000 l. Code 8560175
SAC 800	1.1/4" x 520 / Cod. 8560060	
SAC 1000	1.1/4" x 520 / Cod. 8560060	
SAC 1500	1.1/4" x 670 / Cod. 8560070	Cathodic protection for cylinders 1500/2000 l. Code 8560180
SAC 2000	1.1/4" x 670 / Cod. 8560070	Cathodic protection for cylinders 3000/5000 l. Code 8560185
SAC 3000	1.1/4" x 700 / Cod. 8560080	
SAC 5000	1.1/2" x 640 / Cod. 8560100	

TABLE OF HEATING ELEMENT APPLICABILITY TO CYLINDERS

Heating element model*					Water heating time from 15° C to 60 °C (expressed in minutes) <i>The heating times outlined are approximate</i>					
CODE	Power (kW)	Voltage (Volt)	Connection	Length (mm)	SAC 300	DAC 500	SAC 800	SAC 1000	SAC 1500	SAC 2000
8601000	1	220 V / MF	G 1.1/4"	295	960 min.	1580 min.	2520 min.	3150 min.	4720 min.	6300 min.
8601650	1.65	220 V / MF	G 1.1/4"	450	580 min.	970 min.	1550 min.	1920 min.	2870 min.	3820 min.
8602000	2	220 V / MF	G 1.1/4"	515	n.a.	800 min.	1270 min.	1580 min.	2370 min.	3150 min.
8602600	2.6	220 V / MF	G 1.1/4"	675	n.a.	n.a.	980 min.	1230 min.	1810 min.	2450 min.
8602601	2.6	220 V / MF	G 1.1/4"	360	370 min.	630 min.	980 min.	1230 min.	1830 min.	2450 min.
8603300	3.3	220 V / MF	G 1.1/4"	825	n.a.	n.a.	n.a.	n.a.	1450 min.	1940 min.
8603301	3.3	220 V / MF	G 1.1/4"	435	295 min.	490 min.	780 min.	980 min.	1450 min.	1940 min.
8604001	4	220 V / MF	G 1.1/4"	510	n.a.	410 min.	640 min.	800 min.	1200 min.	1600 min.
8705000	5	380 V / TF	G 1.1/2"	445	200 min	330 min	520 min.	640 min.	950 min.	1300 min.
8706000	6	380 V / TF	G 1.1/2"	510	n.a.	280 min	430 min.	540 min.	800 min.	1060 min.
8708000	8	380 V / TF	G 1.1/2"	670	n.a.	n.a.	330 min.	420 min.	610 min.	800 min.
8710000	10	380 V / TF	G 1.1/2"	820	n.a.	n.a.	n.a.	n.a.	490 min.	640 min.
8712000	12	380 V / TF	G 1.1/2"	970	n.a.	n.a.	n.a.	n.a.	410 min.	540 min.

n.a. =Heating element not applicable

SEE TABLE OF SYMBOLS
IN THE SHUTTER OF THE
COVER

