

SC/E

GALVANIZED TANKS FOR COLD WATER, WITHOUT CE CERTIFICATION

(100 - 5.000 LITRES)

SC/E 750 - 5000

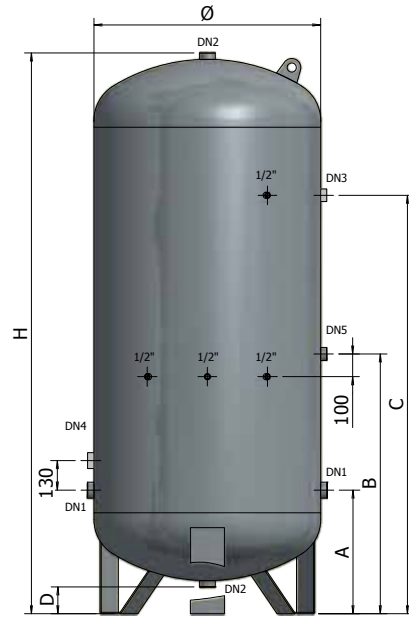

SC/E 100 - 500

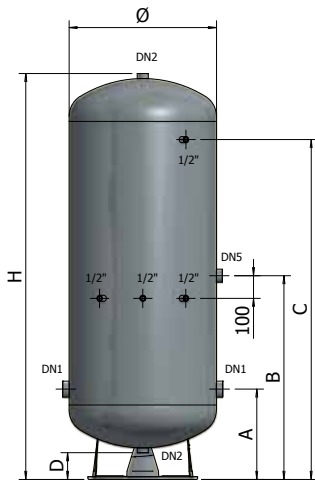

SC/E2 100 - 500

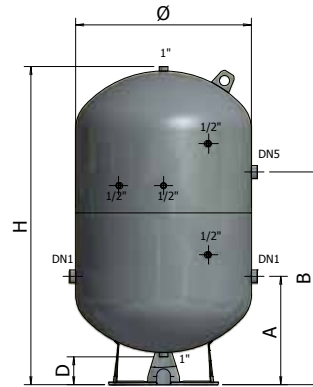

For drinking water



Galvanized



For pressurisation systems

Characteristics:

- Min./max. working temperature: -10° - +50°C

Reference standard:

- Complies with Art. 3.3 of the European Directive 97/23/EC (PED) with CE marking.

The SC/E cold water storage tanks can be used as first water tanks that are not pressurised or as pressurised storage tanks for cold water (accumulation without the air cushion).

WARRANTY: 2 YEARS

DIMENSIONS

MODEL	CODE	LITRES	P max	mm	mm	A	B	C	D	DN1	DN2	DN3	DN4	DN5	NOTES
SC/E2 100	1550101	100	10	500	785	315	490	-	90	1"	-	-	-	1"1/4	
SC/E2 200	1550209	200	10	600	1025	360	670	-	110	1"1/4	-	-	-	1"1/4	
SC/E2 300	1550306	300	10	650	1210	375	795	-	110	1"1/4	-	-	-	1"1/4	
SC/E2 500	1550403	500	10	775	1410	480	940	-	120	1"1/2	-	-	-	1"1/2	
SC/E 100	1550110	100	10	400	970	270	420	770	90	1"	1"1/4	-	-	1"1/4	
SC/E 200	1550220	200	10	500	1255	345	635	985	110	2"	1"1/4	-	-	1"1/2	
SC/E 300	1550350	300	10	550	1490	395	675	1175	100	2"	1"1/4	-	-	1"1/2	
SC/E 500	1550420	500	10	650	1785	390	790	1490	105	2"	1"1/4	-	-	1"1/2	
SC/E 750	1550501	750	6	800	1905	470	870	1725	145	2"	1"1/2	-	-	1"1/2	
SC/E 1000	1550608	1000	6	800	2155	470	925	1800	145	2"	1"1/2	-	-	1"1/2	
SC/E 1500	1550705	1500	6	1000	2475	545	1045	1845	145	2"	2"	-	-	1"1/2	
SC/E 2000	1550802	2000	6	1100	2445	525	1075	2025	135	2"	2"	-	-	1"1/2	
SC/E 3000	1551001	3000	6	1250	2830	565	1255	2355	115	2"1/2	2"	1"1/2	2"1/2	1"1/2	
SC/E 5000	1551205	5000	6	1600	3040	675	1365	2465	130	2"1/2	2"	1"1/2	2"1/2	1"1/2	

